



IPU10



**Universal - for lifting in any direction**

- Available in capacities of .5 thru 30 metric tons (higher Working Load Limits are available upon request).
- Wide variety of jaw openings available: 0 to 155mm.
- Welded alloy steel body for strength and smaller size. Forged alloy components, where required.
- Individually Proof Tested to 2 times the Working Load Limit with certification.
- Company name (Crosby IP), logo, Working Load Limit and jaw opening permanently stamped on body.
- Each product is individually serialized, with the serial number and Proof Load test date stamped on body. User manual with test certificate is included with each clamp.
- Available in a variety of styles:
  - IPU10 - Standard clamp for materials with a surface hardness to 363HV10 (345 HB).
  - IPU10J - Larger jaw opening.
  - IPU10S - For use with stainless steel material.
  - IPU10H - For use with materials with a surface hardness to 472HV10 (450 HB).
- Full 180° turning range for material transfer, turning or moving.
- Lock open, lock closed ability with latch for pretension on material and then release of material.
- For use with materials with a surface hardness to 279HV10. Only 5% minimum WLL is needed.
- Maintenance and repair kits are available.
- Minimum WLL is 5% of maximum WLL for .5t IPU10 only.
- Minimum WLL is 10% of maximum WLL for all other IPU10, IPU10J, IPU10S, IPU10H clamps.

IPU10S



**Model IPU10 / IPU10J / IPU10S / IPU10H**

Load Rated

Model	Working Load Limit (t)*	Stock No.	Weight Each (kg)	Dimensions (mm)									
				Jaw A	B	C	D	E	F	G	H	J	K
IPU10	0.5	2701675	1.9	0 - 16	44	130	216	40	115	42	28	-	11
IPU10	1	2701663	2.4	0 - 20	45	139	225	40	127	42	38	-	11
IPU10	2	2701677	8.5	0 - 35	78	201	368	70	188	64	55	-	16
IPU10	3	2701665	14.8	0 - 40	100	253	436	75	222	78	60	-	20
IPU10	4.5	2701667	16.0	0 - 40	100	253	436	75	227	82	65	-	20
IPU10	6	2701669	24.0	0 - 50	126	302	525	80	292	84	95	44	20
IPU10	9	2701671	29.5	0 - 50	126	325	552	80	310	94	104	44	20
IPU10	12	2701679	57.0	0 - 54	160	392	616	80	433	121	137	41	25
IPU10	16	2701683	79.0	5 - 64	180	463	736	88	492	121	153	45	25
IPU10	22.5	2701687	126.0	5 - 80	222	554	863	110	565	139	186	49	25
IPU10	30	2701691	141.0	5 - 80	222	554	868	110	580	153	186	54	30
<b>With larger jaw opening</b>													
IPU10J	0.5	2701647	1.9	15 - 30	45	128	209	40	128	42	32	-	11
IPU10J	1	2702463	2.5	20 - 40	55	151	221	40	141	42	41	-	11
IPU10J	3	2702465	17.3	40 - 80	115	270	432	75	277	78	67	-	20
IPU10J	4.5	2702467	18.9	40 - 80	115	270	432	75	281	82	72	-	20
IPU10J	6	2702469	26.5	50 - 100	126	302	515	80	336	84	95	44	20
IPU10J	9	2701673	30.5	50 - 100	126	325	550	80	360	94	105	44	20
IPU10J	12	2701681	65.0	54 - 108	178	438	662	80	491	121	136	41	25
IPU10J	16	2701685	85.0	64 - 128	208	521	784	88	562	121	160	45	25
IPU10J	22.5	2701689	149.0	80 - 155	255	628	938	110	660	139	196	49	25
IPU10J	30	2701693	165.0	80 - 155	255	628	942	110	660	153	196	54	30
<b>For stainless steel - with universal hoisting eye</b>													
IPU10S	0.5	2702275	1.9	0 - 16	44	130	216	40	115	42	28	-	11
IPU10S	1	2702263	2.4	0 - 20	45	139	225	40	127	42	38	-	11
IPU10S	2	2702277	8.5	0 - 35	78	201	368	70	188	64	55	-	16
IPU10S	3	2702265	14.8	0 - 40	100	253	436	75	222	78	60	-	20
IPU10S	4.5	2702267	16.0	0 - 40	100	253	436	75	227	82	65	-	20
IPU10S	6	2702269	24.0	0 - 50	126	302	525	80	292	84	95	44	20
IPU10S	9	2702271	29.5	0 - 50	126	325	552	80	310	94	104	44	20
IPU10S	12	2702279	57.0	0 - 54	160	392	616	80	433	121	137	41	25
<b>For very hard materials - with universal hoisting eye</b>													
IPU10H	0.5	2702175	1.9	0 - 16	44	130	216	40	115	42	28	-	11
IPU10H	0.75	2702163	2.4	0 - 20	45	139	225	40	127	42	38	-	11
IPU10H	1	2702177	7.6	0 - 35	78	201	368	70	188	64	55	-	16
IPU10H	2	2702165	14.8	0 - 40	100	253	436	75	222	78	60	-	20
IPU10H	3	2702167	16.0	0 - 40	100	253	436	75	227	82	65	-	20
IPU10H	4.5	2702169	24.0	0 - 50	126	302	525	80	292	84	95	44	20
IPU10H	6	2702171	29.5	0 - 50	126	325	552	70	310	94	104	44	20

Design Factor based on EN 13155 and ASME B30.20. Model IPU10R (remote control opening and closing via a cable) on request. Model IPU10W (wedge) available on request.

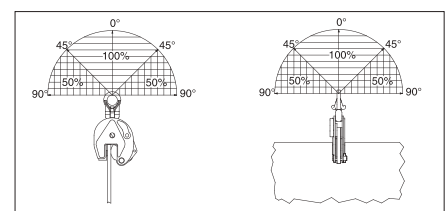
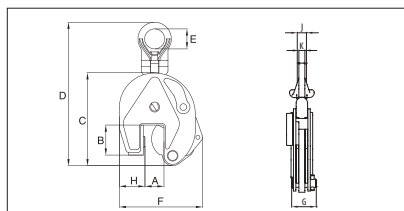



IPNM10N



For use in almost all sectors of industry where, during the lift or transfer, no damage to the material is permitted.

- Available in capacities of .5 , 1 and 2 metric tons (higher Working Load Limits are available upon request).
- Wide variety of jaw openings available: 0 to 40mm.
- Welded alloy steel body for strength and smaller size. Forged alloy components, where required.
- Individually Proof Tested to 2 times the Working Load Limit with certification.
- Company name (Crosby IP), logo, Working Load Limit and jaw opening permanently stamped on body.
- Each product is individually serialized, with the serial number and Proof Load test date stamped on body. User manual with test certificate is included with each clamp.
- Full 180° turning range for material transfer, turning or moving.
- Lock open, lock closed ability with latch for pretension on material and then release of material.
- Material must be clean and dry.
- There is no minimum WLL required.
- Maintenance and repair kits are available.
- Temperature range -20° C to 70° C
- Optional with brake pad lining for temperature range -40° C to +200° C
- Special jaw openings or curved jaws upon request.

IPNM10P



Load Rated

Model IPNM10

Model	Working Load Limit (t)*	Stock No.	Weight Each (kg)	Dimensions (mm)								
				Jaw A	B	C	D	E	F	G	H	K
IPNM10N	0.5	2703811	2.7	0 - 10	84	159	235	40	128	60	42	11
IPNM10N	1	2703738	4.4	0 - 20	97	209	278	40	184	80	56	11
IPNM10	2	2703442	14.5	0 - 40	153	258	396	70	296	100	161	16
With protection cap												
IPNM10P	0.5	2703278	2.8	0 - 10	82	157	221	40	145	68	48	11
IPNM10P	1	2703279	4.5	0 - 20	97	195	276	40	205	82	66	11
With larger jaw opening												
IPNM10NJ	1	2703814	4.7	20 - 37	97	220	321	40	200	80	56	11
IPNM10NJ1	1	2703819	5.5	0 - 25	97	238	351	40	213	80	63	11

\* Design Factor based on EN 13155 and ASME B30.20.

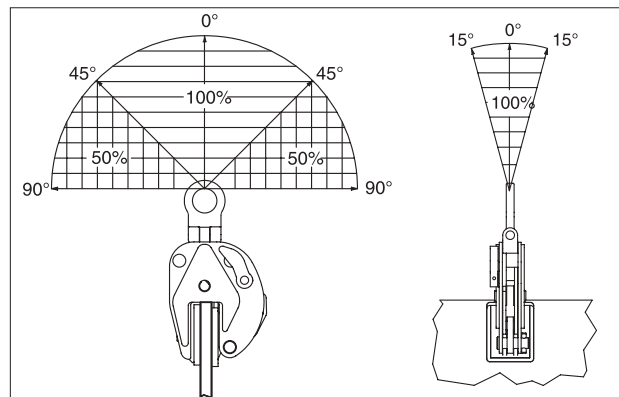
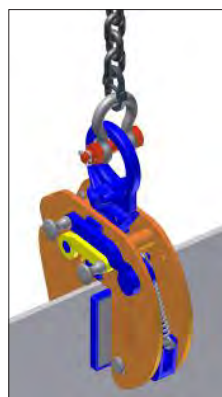
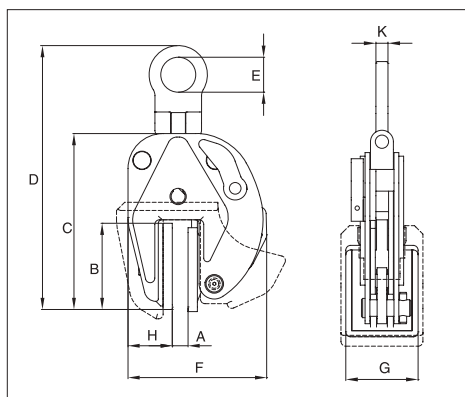

LIFTING CLAMPS & MAGNETS